

Ring Around the Tango™

PATTERN

Featuring the *Bead* MASTER™ Exclusive

TANGO™
Bead

Materials Needed

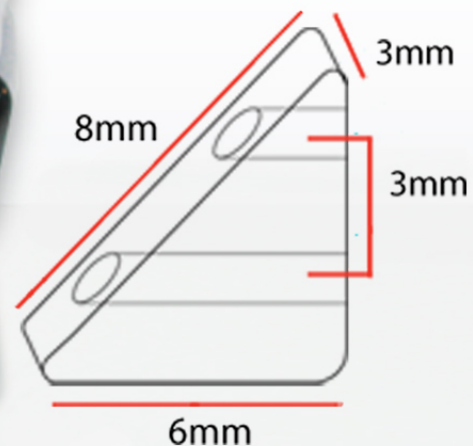

Step 1

Create a Tango™ Tile

Pair 2 Tango™ beads together so that the 2 holes are vertically aligned, forming a square, or Tango™ Tile (A).



Step 2

2 Tango™ Tiles

Stack another Tango™ tile (A) above the original Tango™ tile (A), so that the holes are vertically aligned.



★ Entry Point

● Knot

→ Thread's Direction

2 Tango™ Beads = Tango™ Tile (A)



○ = Seed Bead (B)

Step 3

2 Tango™ Tiles

Using a needle and 24" thread that has a knot at the end, thread both Tango™ tiles (A) through the holes on the left side.

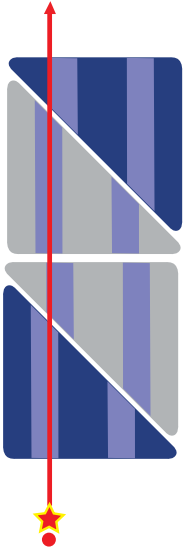

Step 4

2 Tango™ Tiles

Flip the upper Tango™ tile (A) on the thread's axis, so that the Tango™ tiles (A) now form a staggered step shape.

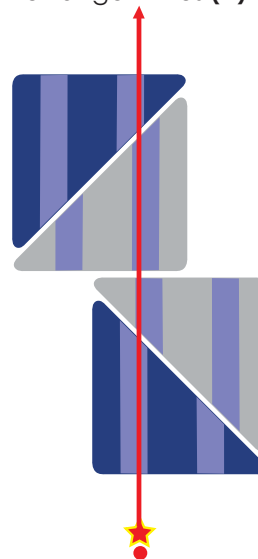

Step 5

2 Tango™ Tiles

Flip both Tango™ tiles (A) over, so the knot is now above the upper Tango™ tile (A) with the thread now going down through both Tango™ Tiles (A).

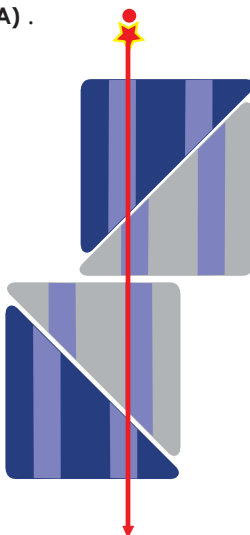

Step 6

3 Tango™ Tiles

Position another Tango™ tile (A) to the right of the lower Tango™ tile (A) aligning the left holes vertically with the right holes of the upper Tango™ tile (A).



Step 7

3 Tango™ Tiles and 2 Seed Beads

Thread 2 seed beads (B) before threading the left side of the lower Tango™ tile (A) and then the right side of the upper Tango™ tile (A). Pull thread to tighten.

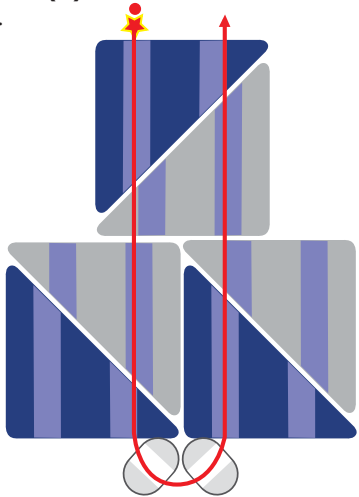

Step 8

3 Tango™ Tiles and 2 Seed Beads

Flip the beads over so that it forms a T shape.

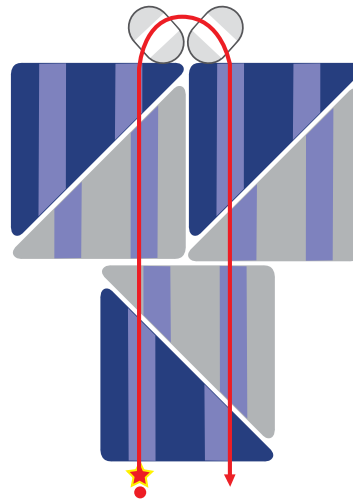

★ Entry Point

• Knot

→ Thread's Direction

2 Tango™ Beads = Tango™ Tile (A)



○ = Seed Bead (B)

Step 9

4 Tango™ Tiles and 4 Seed Beads

Thread another pair of seed beads (B). Add another Tango™ tile (A) to the right of the lower Tango™ tile (A). Thread upwards through the left holes, and up through the right holes of the upper right Tango™ tile (A). Pull thread to tighten.

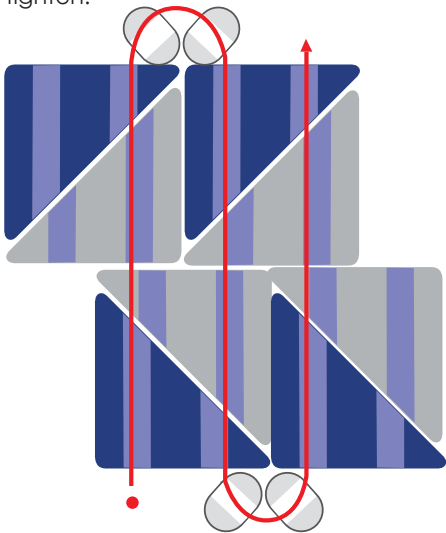

Step 10

5 Tango™ Tiles and 6 Seed Beads

Thread another pair of seed beads (B). Add a new Tango™ Tile (A) continuing down through the left side of it. Continue threading down through the right side of the lower Tango™ tile (A). Pull thread to tighten.

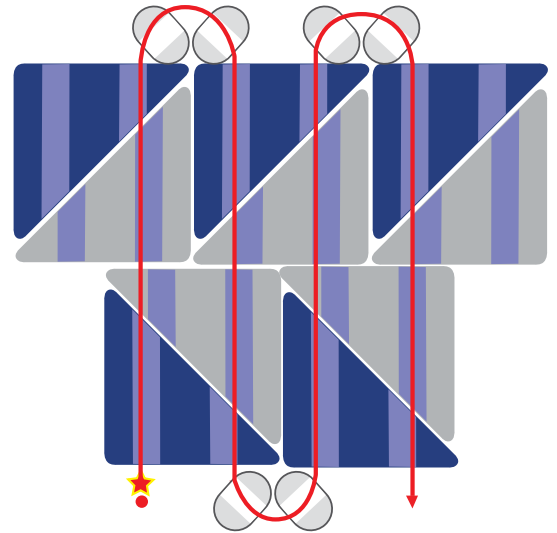

Step 11

6 Tango™ Tiles and 8 Seed Beads

Thread another pair of seed beads (B). Add another Tango™ Tile (A) continuing up through the holes on the left side. Continue threading up through the holes on the right side of the upper Tango™ tile (A). Pull thread to tighten.

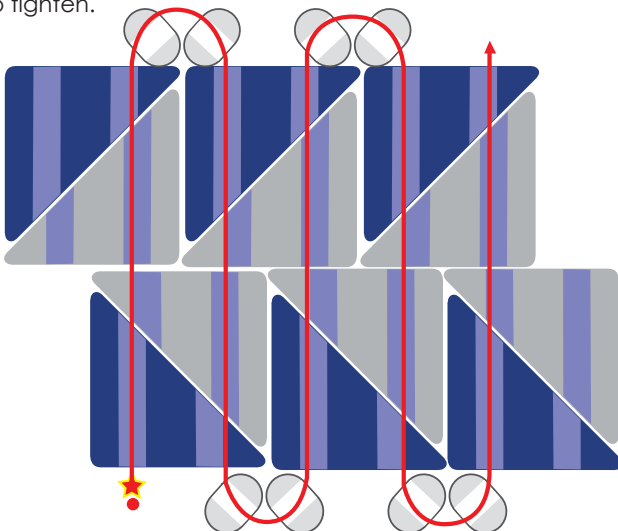

★ Entry Point

• Knot

→ Thread's Direction

2 Tango™ Beads = Tango™ Tile (A)



○ = Seed Bead (B)

Step 12

Join Ends Of Ring

Repeat steps 8 through 11 until you have the desired length.

Bring the end to touch the original Tango™ tile (A) with the knotted entry point, threading 2 more seed beads (B) on upper edge.

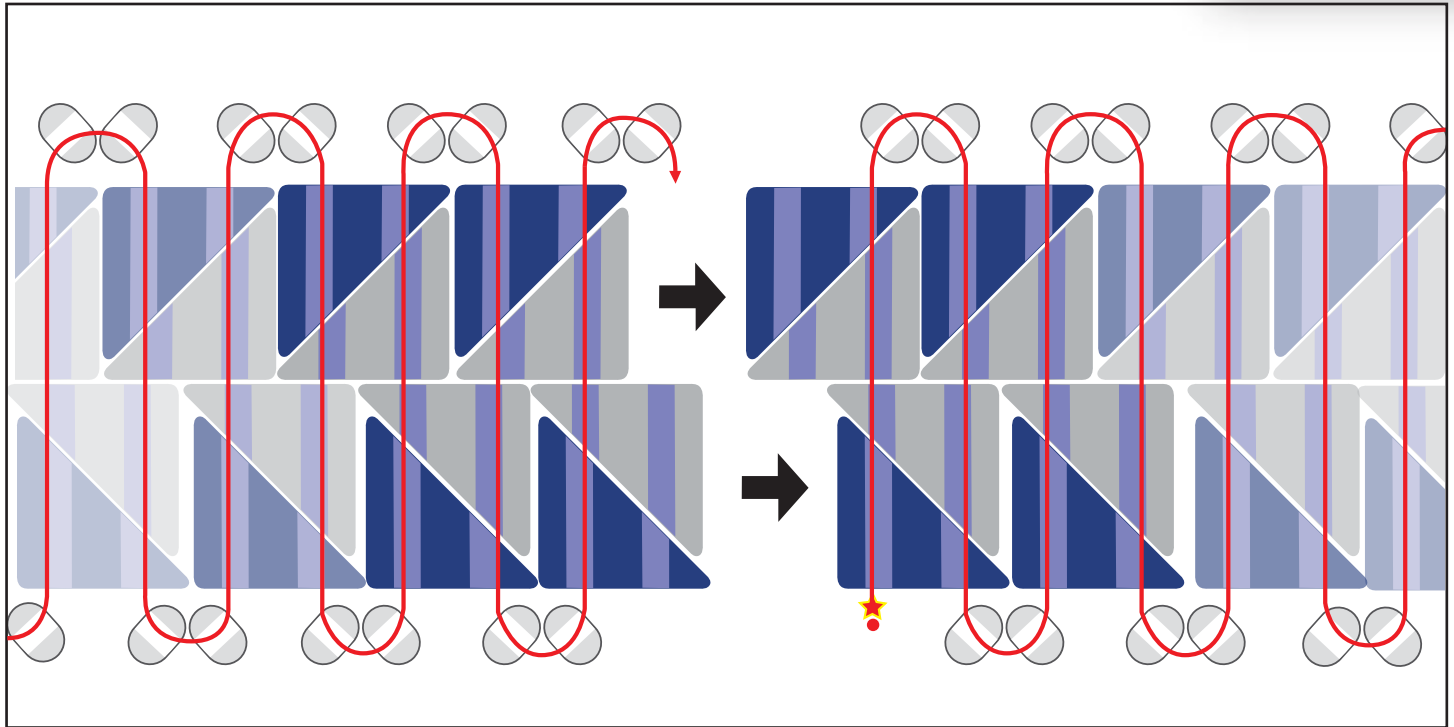

Step 13

Connect and Secure Both Ends to Finish

Complete the circuit by threading the left holes of the original upper Tango™ tile (A), and the right holes of the last Tango™ tile (A). Thread the last pair of seed beads (B) on the lower edge, and retrace 3 previously threaded Tango™ tiles to secure the connection of both ends. Make a knot between the Tango™ tiles (A) and dot with a clear adhesive. With the needle push the glued knot into the hole of a Tango™ bead.

